

TORSION SPRING FRONT OR REAR MOUNT LOW HEADROOM

Supplemental insert

©Copyright 2012 Wayne-Dalton, a Division
Of Overhead Door Corporation

Part No. 333895

REV3 02/29/2012

This supplemental installation instruction is to be used as a supplement to the main Installation Instruction and Owner's Manual provided with the door. The instructions included in this document are ONLY those which deviate from the standard installation. All WARNINGS and CAUTIONS listed in the main manual are applicable to this supplemental instruction as well.

www.Wayne-Dalton.com

INSTALLATION

1

Cutting Vertical Track

Vertical track must be cut to the proper length prior to installation.

IMPORTANT: DOORS THAT ARE 7'-0" OR 8'-0" IN HEIGHT DO NOT REQUIRE CUTTING THE VERTICAL TRACK.

Determine the radius of your horizontal track. Using this measurement, refer to the vertical track cutting chart to determine the length of the vertical track. Cut the track off at the TOP. Two holes must be drilled into the top of the cut vertical track. Refer to the illustration shown for hole locations. Use a 5/16" drill bit, as shown in FIG. 1.1.

Vertical Track Cutting Chart

Horizontal Track Radius	Vertical Track Cut Length
0" Rad	Door Height Minus 17"
3-1/2" LHR	Door Height Minus 15"
6-1/2" LHR	Door Height Minus 12"

Repeat for other vertical track.

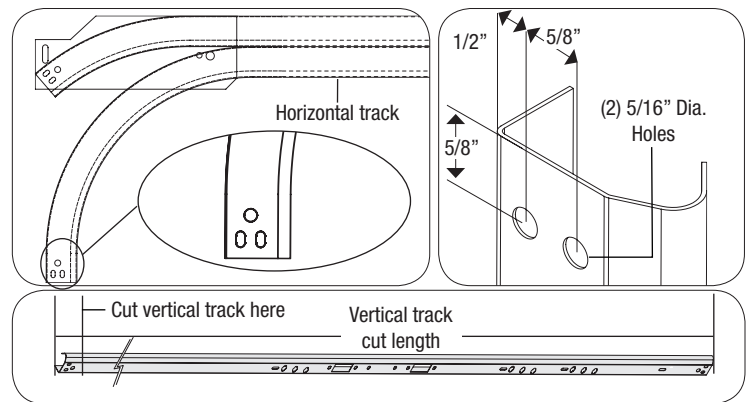

FIG. 1.1

2

Fully Adjustable Jamb Brackets

The bottom jamb bracket is always the shortest bracket included with your door. To attach the bottom jamb bracket, locate the first set of quick install features of the vertical track. Align the slot in the jamb bracket with the slot above the quick install features in the vertical track. The long side of the bracket is placed against the track and with the tabs away from the track. Fasten the jamb bracket finger tight, using (1) 1/4" - 20 x 5/8" track bolt and (1) 1/4" - 20 flange hex nut. To attach the top jamb bracket, locate the third set of quick install features of the vertical track. Align the slot in the jamb bracket with the slot above the quick install features in the vertical track. The long side of the bracket is placed against the track. Fasten the jamb bracket finger tight, using (1) 1/4" - 20 track bolt and (1) 1/4" - 20 flange hex nut, as shown in FIG. 2.1.

Repeat for other vertical track.

NOTE: The jamb bracket fasteners are to be tightened when the vertical track is secured to the jamb.

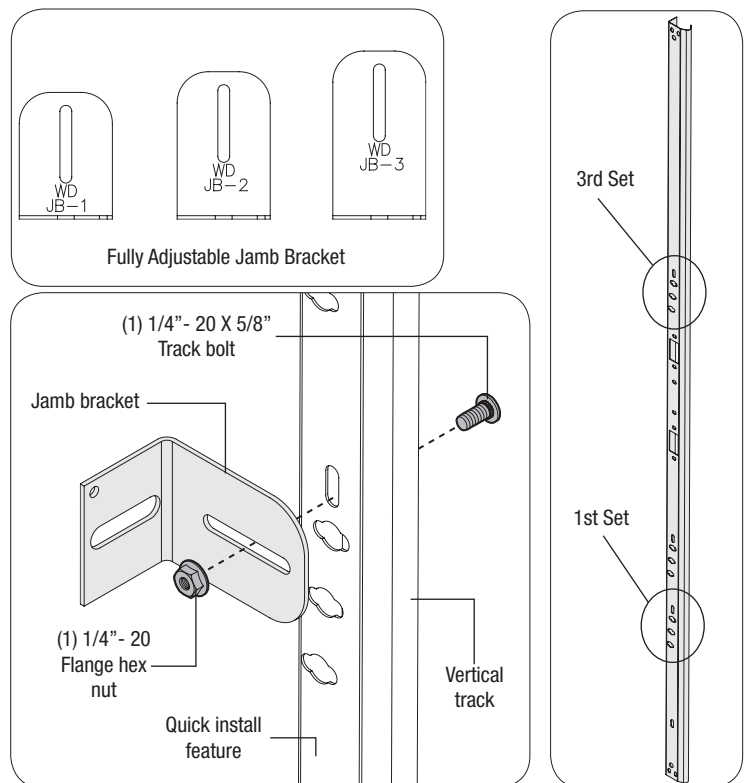

FIG. 2.1

Bottom Bracket Installation

Identify the low-headroom bottom brackets provided with your door (**A, B or C**). Place them, left and right onto the bottom corners of the section. Seat the bottom brackets against the edge of the section, as shown in **FIG. 3.1** and **3.2**.

FOR LOW HEADROOM BOTTOM BRACKET (A):

Secure the low headroom bottom bracket to the section with four 1/4" - 20 x 11/16" self drilling screws, as shown in **FIG. 3.1**.

Place roller into holes of each bottom bracket, as shown in **FIG. 3.1**.

NOTE: (For dealer use only) Install one additional 1/4" - 14 x 5/8" tamper resistant screw, as shown in **FIG. 3.1**.

FOR LOW HEADROOM BOTTOM BRACKET (B):

Secure the low headroom bottom bracket to the section with four 1/4" - 20 x 2 1/2" carriage bolts and four 1/4" - 20 flange hex nuts, as shown in **FIG. 3.2**.

Place roller into holes of each bottom bracket, as shown in **FIG. 3.2**.

NOTE: (For dealer use only) Install one additional 1/4" - 14 x 5/8" tamper resistant screw, as shown in **FIG. 3.2**.

FOR LOW HEADROOM BOTTOM BRACKET (C):

Secure the low headroom bottom bracket to the section with four 1/4" - 20 x 11/16" self drilling screws, as shown in **FIG. 3.3**.

NOTE: (For dealer use only) Install one additional 1/4" - 14 x 5/8" tamper resistant screw, as shown in **FIG. 3.3**.

Attach the counter balance cable to the low-headroom bottom brackets using clevis pins. Secure the clevis pins to bottom brackets using a 5/16" flat washer and cotter pin, as shown in **FIG. 3.4**.

NOTE: Place roller into the factory attached bottom brackets, as shown in **FIG. 3.5**.

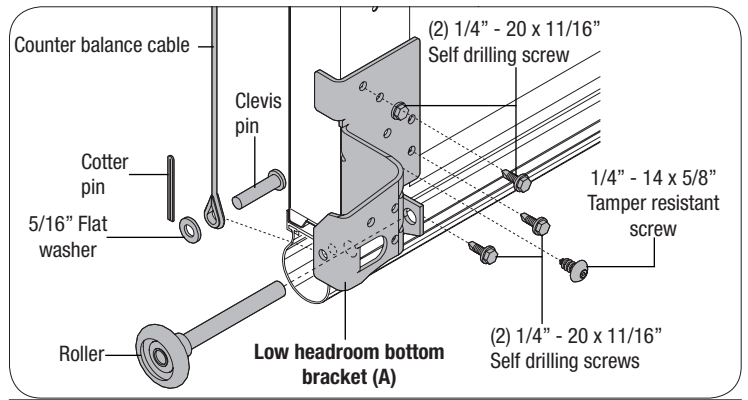

FIG. 3.1

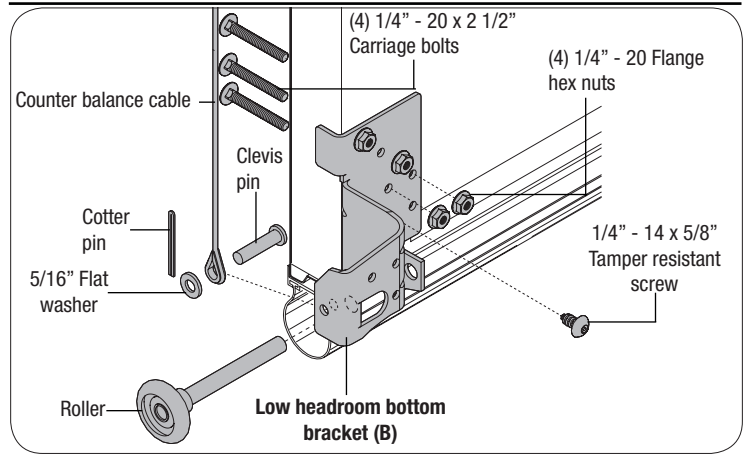

FIG. 3.2

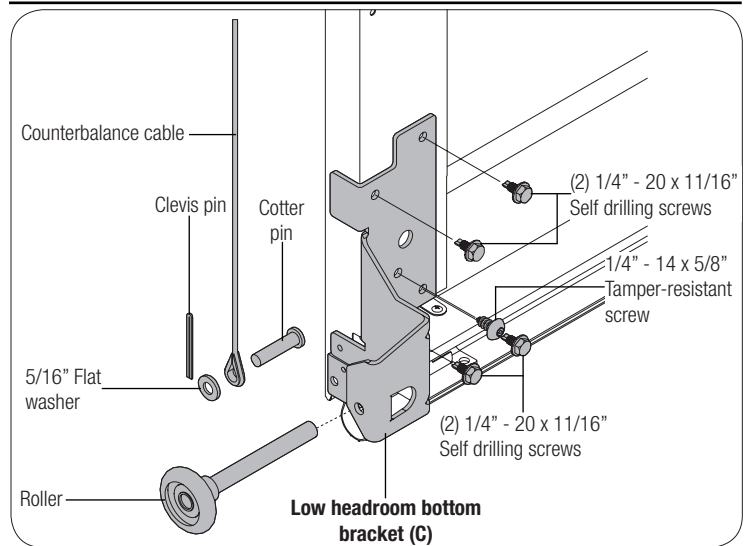

FIG. 3.3

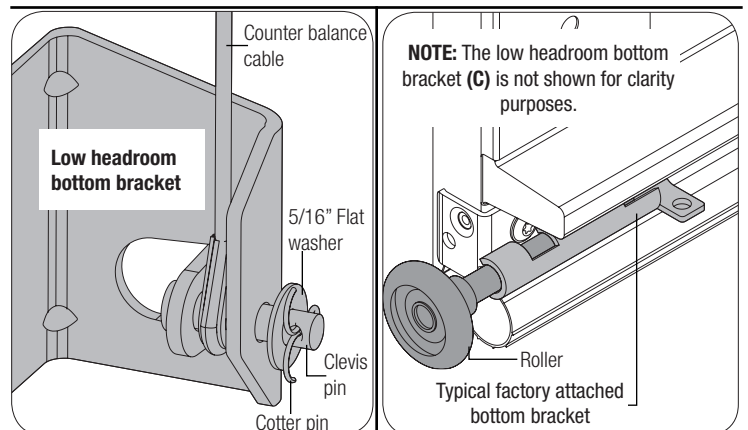

FIG. 3.4

FIG. 3.5

Low Headroom Top Bracket

Identify the low-headroom top brackets provided with your door (**A, B, C or D**). Push the top section of door out against the jamb until the section is parallel with the other sections of the door. Starting with the left hand side, align the edge of top bracket with the edge of section.

NOTE: When installing the top brackets, the top section must be vertically aligned with the rest of the sections from the side view. If needed reposition top bracket(s) to achieve vertical alignment.

FOR LOW HEADROOM TOP BRACKET (A):

Secure the low headroom top bracket to the section by placing one 1/4" - 20 x 11/16" self drilling screw through the lower slot of bracket. Adjust the low headroom top bracket if necessary and secure two more 1/4" - 20 x 11/16" self drilling screws through the top holes, as shown in **FIG. 4.1**.

Repeat the same process for the other side.

FOR LOW HEADROOM TOP BRACKET (B) OR (C):

NOTE: The LHR top bracket comes pre-assembled, as shown in **FIG. 4.3** or **FIG. 4.4**. Locate the edge of the top section and seat the top bracket on male part of the top section, as shown in **FIG. 4.2**.

Attach the top bracket to the top section (B):

1. Attach one 1/4" - 20 x 11/16" self-drilling screw to the top bracket assembly.
2. Attach two 1/4" - 20 x 11/16" self-drilling screws to the top bracket assembly.
3. Attach two #12 x 1/2" phillips head screws on the opposite side of top bracket assembly.

Insert a roller into the top bracket slide, as shown in **FIG. 4.3**. Repeat the same process for the other side.

Attach the top bracket to the top section (C):

1. Attach one 1/4" - 14 x 5/8" self-tapping screw to the top bracket assembly.
2. Attach two 1/4" - 20 x 11/16" self-drilling screws to the top bracket assembly.
3. Attach two #12 x 1/2" phillips head screws on the opposite side of top bracket assembly.

Insert a roller into the top bracket slide, as shown in **FIG. 4.4**. Repeat the same process for the other side.

REVERSING THE TOP SLIDE (B) OR (C), IF NEEDED:

NOTE: Depending on your application, you may need to reverse the top bracket slide for more adjustment, if needed, prior to securing it to the top bracket base.

Remove the top bracket slide by removing the two 1/4" - 20 x 5/8" carriage bolts, two retention washers and two 1/4" - 20 flanged hex nuts. Flip the top bracket slide in the opposite direction. Loosely fasten the top bracket slide to the bracket using two 1/4" - 20 x 5/8" carriage bolts, two retention washers and two 1/4" - 20 flanged hex nuts, as shown in **FIG. 4.5** or **FIG. 4.6**.

NOTE: The retention washers must be fully seated against the top bracket base to ensure the anti-twist feature on the top bracket slide engages in the slotted hole in the top bracket base.

FOR LOW HEADROOM HORIZONTAL TRACK (D):

NOTE: This is a traditional low headroom windload top bracket.

Vertically align the flat portion of roller slide with the endcap and u-bar at the top of top section. Fasten roller slide using (2) 1/4" - 14 x 7/8" self drilling screws, as shown in **FIG. 4.7**. Repeat the same process for the other side.

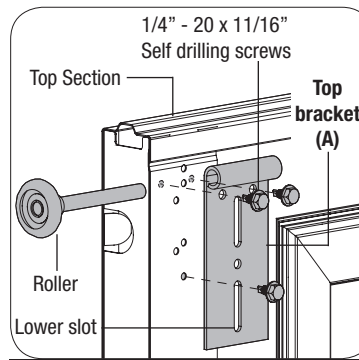

FIG. 4.1

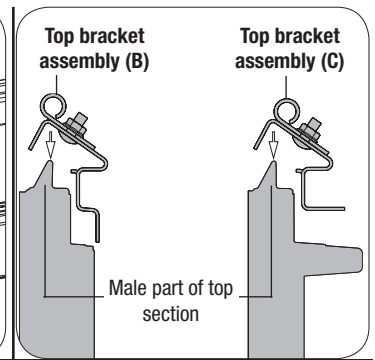

FIG. 4.2

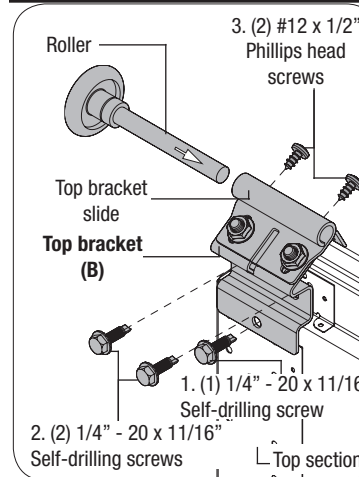

FIG. 4.3

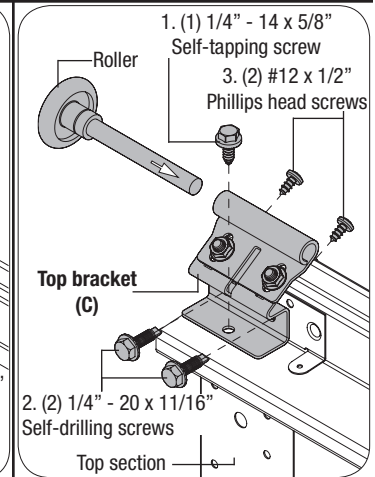

FIG. 4.4

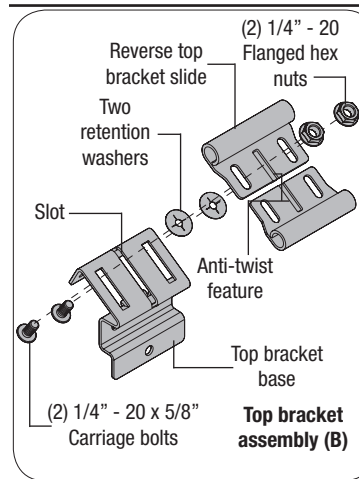

FIG. 4.5

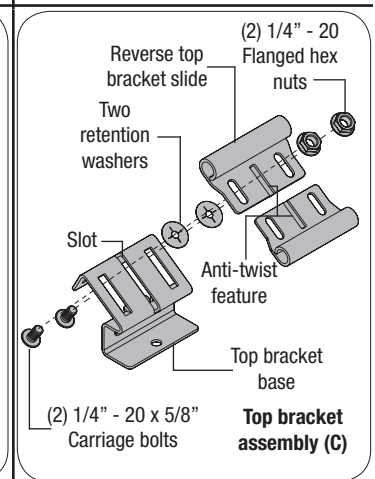

FIG. 4.6

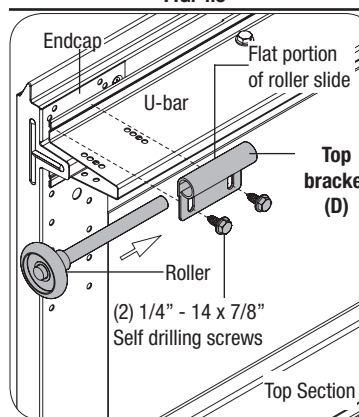

FIG. 4.7

WARNING

DO NOT RAISE DOOR UNTIL HORIZONTAL TRACKS ARE SECURED AT REAR, AS OUTLINED IN REAR SUPPORT INSTALLATION, OR DOOR COULD FALL FROM OVERHEAD POSITION CAUSING SEVERE OR FATAL INJURY.

5

Universal Horizontal Track

Place the horizontal track overtop of the previously installed vertical track. Align the bottom of the horizontal track with the top of the vertical track.

Secure the horizontal track to the corresponding flagangle with (2) 1/4" - 20 x 9/16" track bolts and nuts. Level the horizontal track and secure the upper curve to the flagangle using (1) 3/8" - 16 x 3/4" hex head bolt and (1) 3/8" - 16" hex nut, as shown in **FIG. 5.1**.

Repeat for other side.

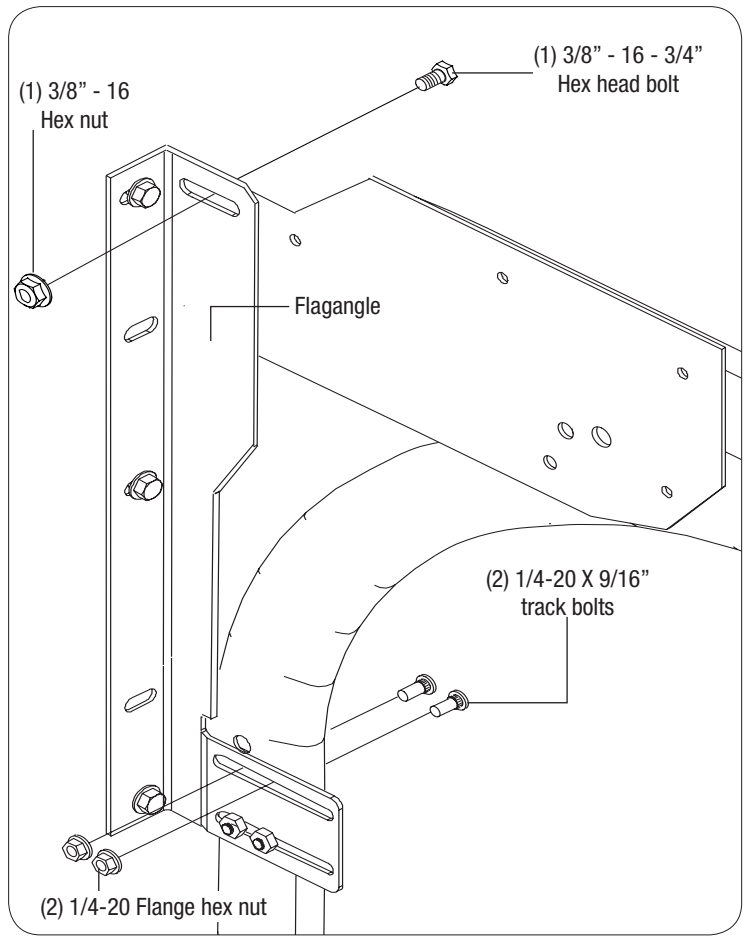

FIG. 5.1

6

End Bearing Bracket Front Mount Springs

Place the left and right end bearing fixtures above the flagangles. Attach the fixtures to the jamb using (3) 5/16" x 1-5/8" lag bolts, as shown in **FIG. 6.1**.

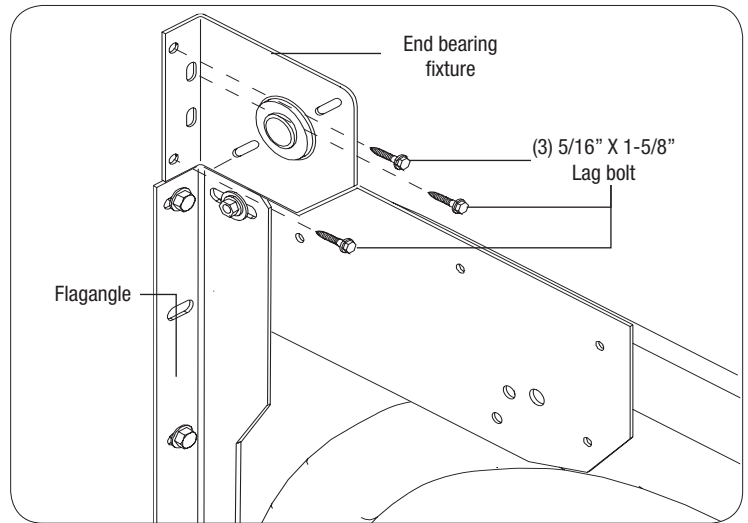

FIG. 6.1

7

Center Bearing Bracket Front Mount Springs

Locate the center of the door and mark a vertical pencil line on the mounting surface. Then measure the distance from the top of the door to the center of the bearing on the end bearing fixture. Mark a horizontal line on the mounting surface, the measured distance up from the top of the door. Offset the center bearing bracket 1-1/2" off center on the spring mounting surface and center the bearing hole in the bracket over the horizontal line so that the torsion shaft will lay level through the brackets when installed. Attach the bracket to the mounting surface using (2) 5/16" x 2" lag bolts and (1) tamper resistant lag screw, as shown in **FIG. 7.1**.

NOTE: If you do not have the proper tool to install the tamper-resistant lag screw, use another 5/16" x 1-5/8" lag screw.

IMPORTANT: USE A 5/16" X 1-5/8" TAMPER RESISTANT LAG SCREW ONLY IF MOUNTING SURFACE IS MOUNTED OVER MASONRY. TAMPER-RESISTANT LAG SCREW MUST BE ATTACHED THROUGH THE BOTTOM HOLE OF THE CENTER BEARING BRACKET.

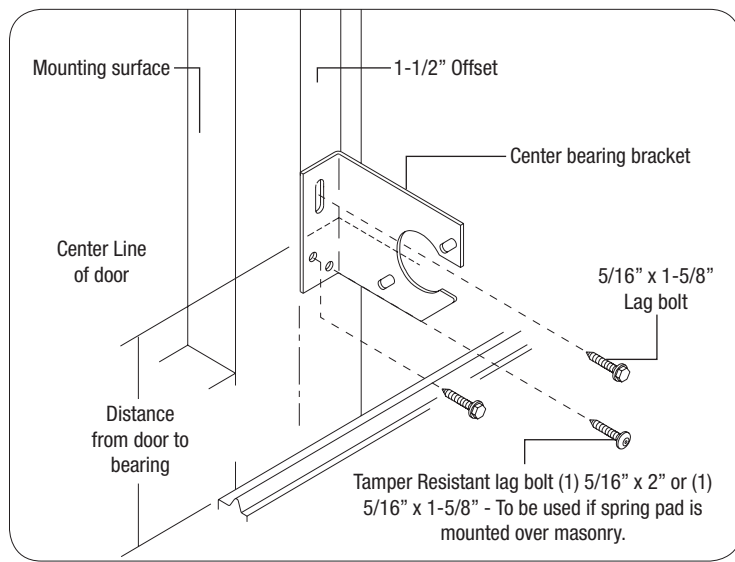

FIG. 7.1

8

Torsion Shaft Assembly Front Mount Springs

Place the torsion shaft on the floor in front of the door. Facing the door, slide the nylon center bearing over the end of the tube until it is centered on the shaft. Slide the spring with the black winding cone over the left hand end of the tube. Slide the spring with the red winding cone (if applicable) over the right hand end of the shaft. If applicable, slide the set collar over both ends of the torsion shaft, as shown in **FIG. 8.1**.

NOTE: Front mount torsion shaft assembly for LHR doors are opposite from standard lift doors.

NOTE: Set collars are only included when outside pull bottom fixtures and a 2 piece solid shaft are supplied.

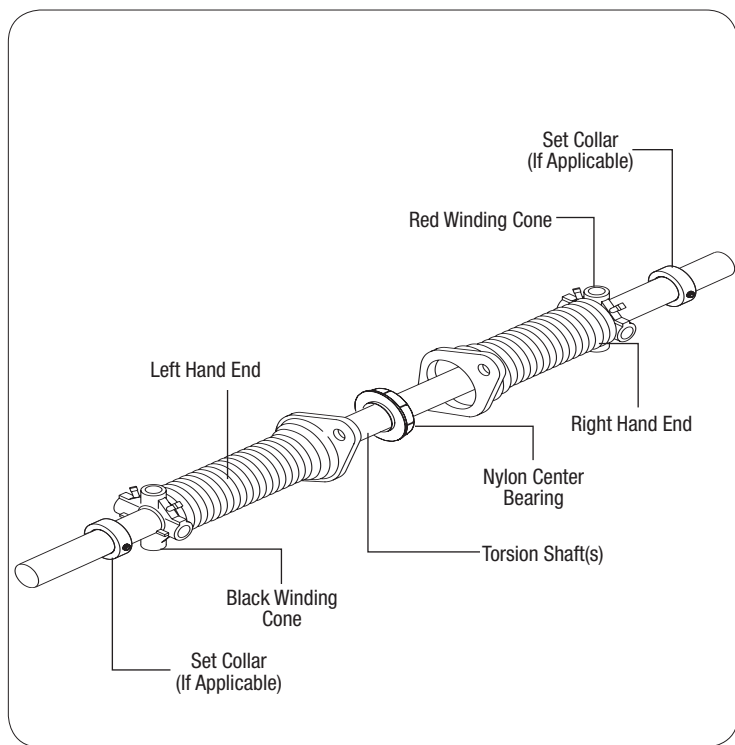

FIG. 8.1

12

Portland Track Bearing Bracket Installation Rear Mount Springs Only

Level horizontal track and drill (2) $\frac{3}{8}$ " dia. holes in the ends of the track as shown. Secure bearing brackets to the rear support angle using (2 or 4) $\frac{3}{8}$ -16 x $\frac{3}{4}$ " truss head bolts and nuts, as shown in FIG. 12.1.

NOTE: The orientation of the bearing brackets may be optimized for different low-head-room applications. See Figure for ceiling mount bearing brackets.

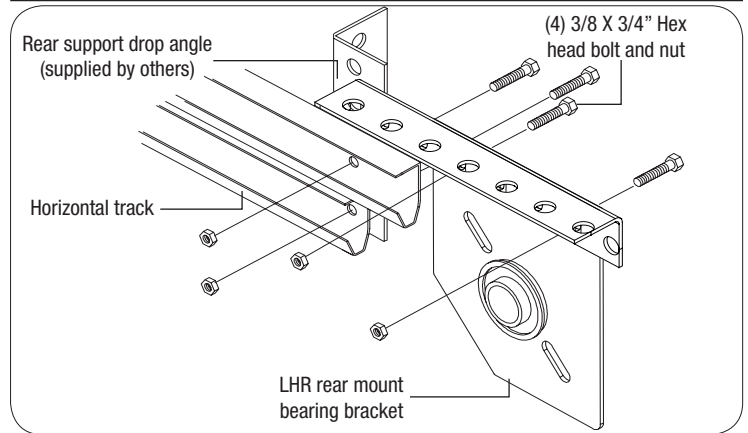
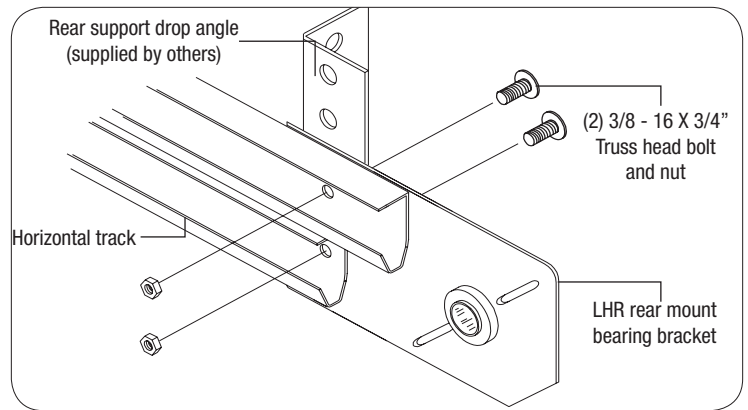

FIG. 12.1

13

Cable Sheave And Torsion Shaft Assembly For Rear Mount Springs Only

Cable Sheave:

Using the appropriate hole in the sheave plate as a guide, drill a $\frac{13}{32}$ " dia. hole through the sheave plate and track. Place a $\frac{3}{8}$ -16 x $1\frac{1}{2}$ " truss head bolt through the drilled hole and slide a steel sheave over the end of the bolt as shown. Secure the sheave using (1) $\frac{3}{8}$ " hex nut. Repeat for the other side, then loop the counterbalance cables over each sheave, as shown in FIG. 13.1.

Torsion Shaft Assembly For Rear Mount Springs Only:

Place the torsion shaft on the floor at the end of the horizontal track. Facing the door, slide the center bearing bracket over the end of the tube until it is centered on the shaft. Slide the spring with the black winding cone over the left hand end of the tube. Slide the red spring (if applicable) over the right end of the shaft as shown in FIG. 13.2.

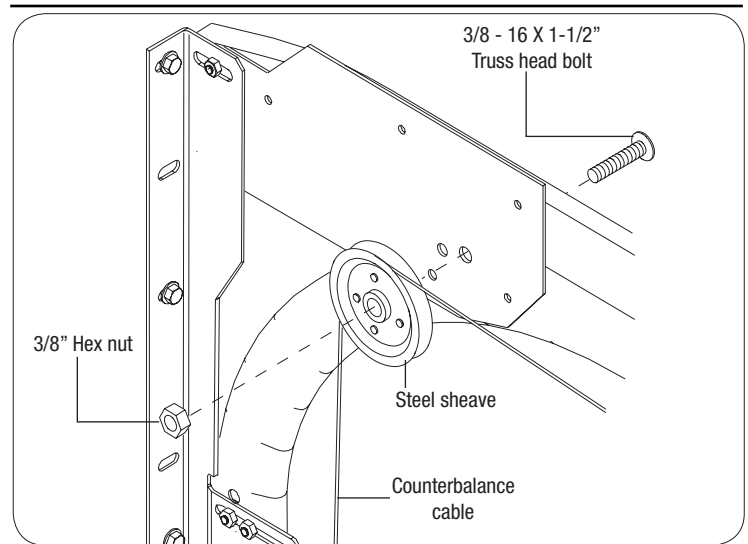

FIG. 13.1

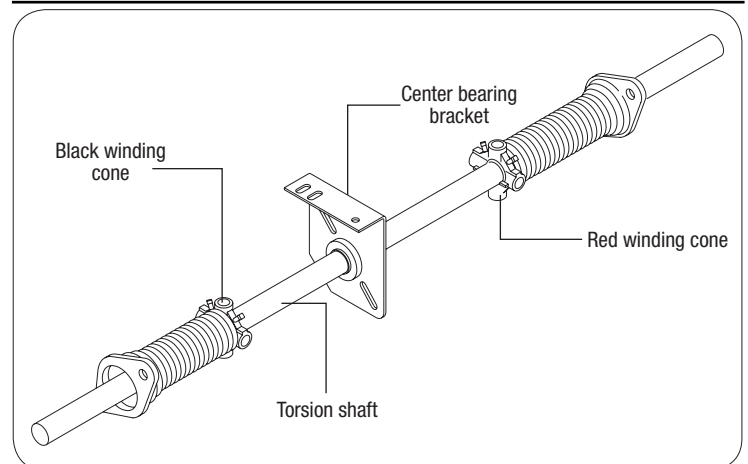

FIG. 13.2

Torsion Shaft Installation Rear Mount Springs Only

Lift the torsion shaft off the floor. Slide one end of the shaft through the end bearing bracket. Extend the shaft through the bearing until the opposite end of the shaft can be inserted into the other bracket. Equalize the amount that the shaft protrudes on each side. Slide the center bearing bracket to the center of the torsion shaft. Secure the bracket to the ceiling using perforated angle or wood blocking. Place the stationary cone(s) of the torsion springs in line with the slots in the end bearing brackets and secure using (2) 3/8-16 x 1-1/2" hex head bolts and nuts (each) as shown. Place the black drum over the left end of the torsion shaft (inside looking out) and the red drum over the right end. Apply locking pliers to the track above a roller before winding springs. Ensure that counterbalance cables are over the steel sheaves and wrap the counterbalance cables over the tops of the drums. Hook the cable stops behind the notches in the drums. Rotate the drums to add tension to the cables. Tighten the set screws for each drum. Clamp locking pliers onto the torsion shaft so that cables maintain tension. Cables should terminate at 6 O'clock position minimum (as shown), and cable tension should be equal for both sides. Check the spring warning tag for number of turns required. Using approved winding bars, wind the springs upward to the required number of turns, as shown in FIG. 14.1 and FIG. 14.2.

NOTE: See provided installation manual for information regarding adjusting spring tension.

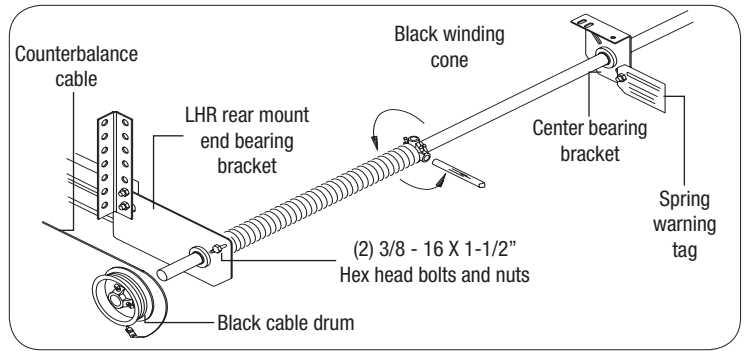

FIG. 14.1

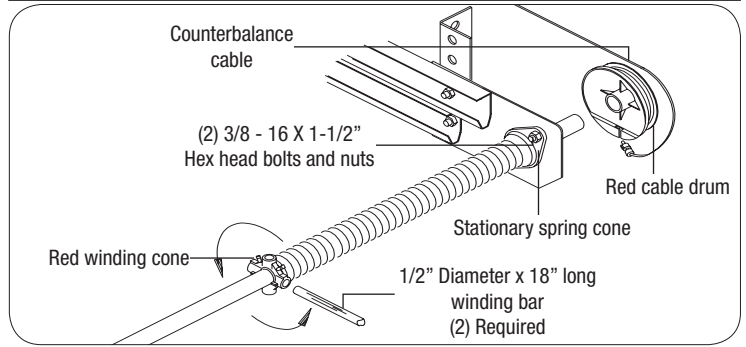

FIG. 14.2

Rear Support Installation

Raise the door until the top section and half of the next section are in a horizontal position. Do not raise door any further since rear of horizontal track is not yet supported.

WARNING

RAISING DOOR FURTHER CAN RESULT IN DOOR FALLING AND CAUSE SEVERE OR FATAL INJURY.

Clamp a pair of vice clamps on the vertical tracks just above the second roller on one side, just below the second roller on the other side. This will prevent the door from raising or lowering while installing the rear support. Using perforated angle, 5/16" x 1-5/8" hex head lag screws and 5/16" bolts with nuts (may not be supplied), fabricate rear support for horizontal tracks. Attach horizontal tracks to the rear supports with 5/16" - 18 x 1-1/4" hex bolts and nuts (may not be supplied). Horizontal tracks must be level and parallel to door within 3/4" maximum of door edge, as shown in FIG. 15.1 through FIG. 15.3.

WARNING

KEEP HORIZONTAL TRACK PARALLEL AND WITHIN 3/4" MAXIMUM OF DOOR EDGE, OTHERWISE DOOR COULD FALL, RESULTING IN SEVERE OR FATAL INJURY.

IMPORTANT: DO NOT SUPPORT THE WEIGHT OF THE DOOR ON ANY PART OF THE HORIZONTAL TRACK HANGER THAT CANTILEVERS 4" OR MORE BEYOND A SOUND FRAMING MEMBER.

NOTE: If rear supports are to be installed over drywall, use 5/16" x 2" hex head lag screws, and make sure lag screws engaged solid structural lumber.

NOTE: 26" angle must be attached to sound framing members and nails should not be used.

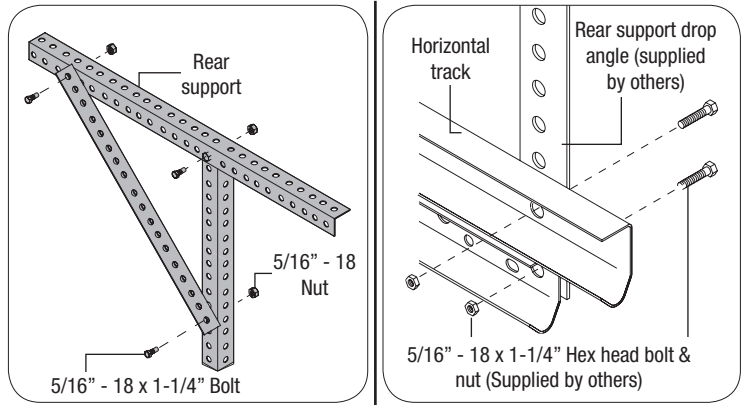

FIG. 15.1

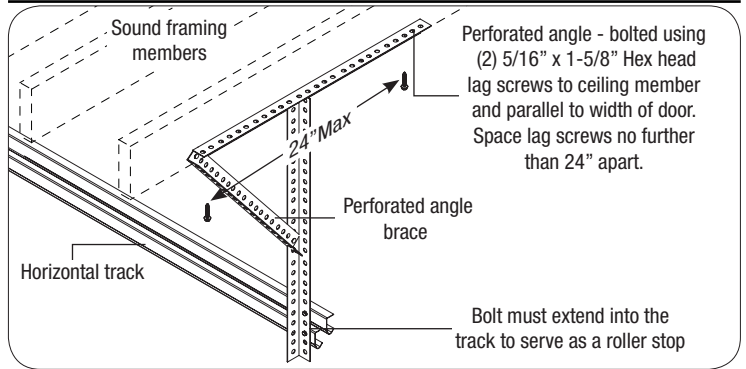

FIG. 15.2

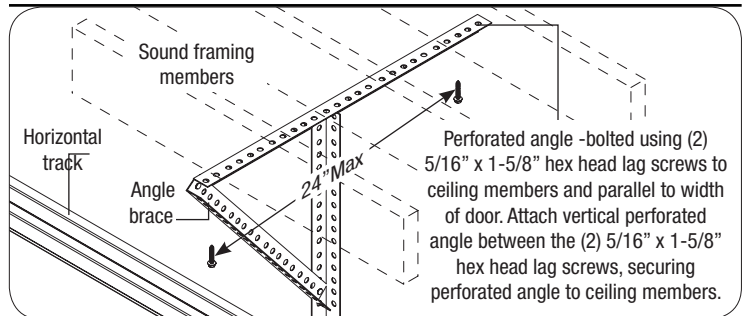

FIG. 15.3