

Low Headroom Rear Mount TorqueMaster®



Supplemental Instruction Insert

This supplemental installation instruction is to be used as a supplement to the main Installation Instruction and Owner's Manual provided with the door. The instructions included in this document are only those which deviate from the standard installation. All warnings and cautions listed in the main manual are applicable to this supplemental instruction as well.

www.Wayne-Dalton.com

1 Bottom Corner Bracket

Tools Required: Power drill, 7/16" Socket driver, Tape measure, Saw Horses, Safety glasses, Leather gloves

Identify the low-headroom bottom corner brackets provided with your door (**A OR B**). Place them, left and right onto the bottom corners of the bottom section. Seat the bottom corner brackets against the edge of the bottom section, as shown.

FOR LOW HEADROOM BOTTOM CORNER BRACKET (A): Secure the low headroom bottom corner bracket to the bottom section with four 1/4" - 20 x 11/16" self drilling screws. Place a short stem track roller into the holes of each bottom corner bracket, as shown.

NOTE: (For dealer use only) Install one additional 1/4" - 14 x 5/8" tamper resistant screw, as shown.

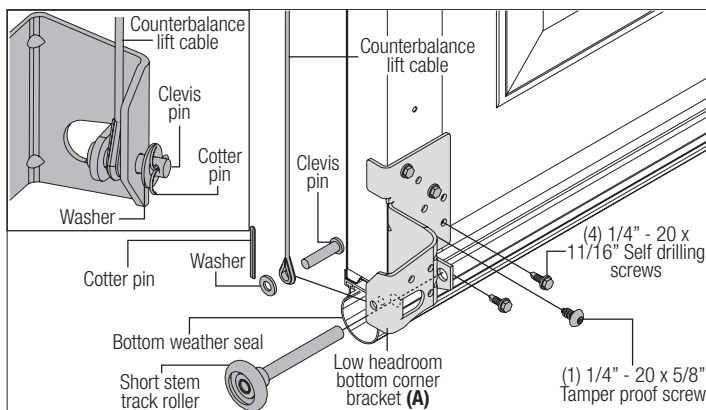

FOR LOW HEADROOM BOTTOM CORNER BRACKET (B): Secure the low headroom bottom corner bracket to the bottom section with four 1/4" - 20 x 11/16" self drilling screws, as shown.

NOTE: (For dealer use only) Install one additional 1/4" - 14 x 5/8" tamper resistant screw, as shown.

Attach the counterbalance lift cable to the low-headroom bottom brackets using clevis pins. Secure the clevis pins to bottom corner brackets using a 5/16" flat washer and cotter pin, as shown.

NOTE: Place short stem track roller into the factory attached bottom corner brackets, as shown.

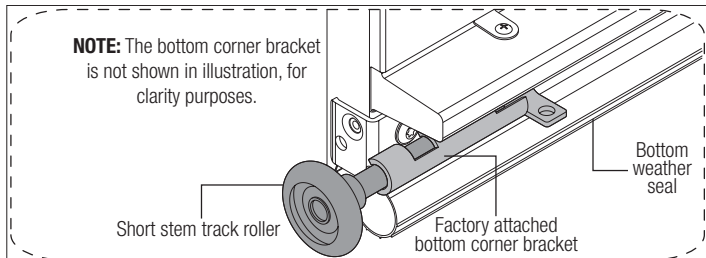
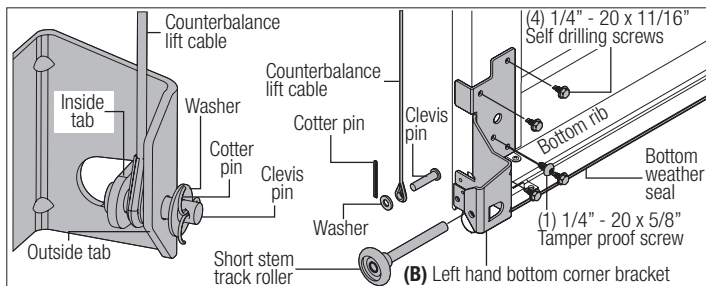

NOTE: The bottom corner bracket is not shown in illustration, for clarity purposes.

2 Quick Install Jamb Brackets

Tools Required: Tape measure, Safety glasses, Leather gloves

NOTE: If you do not have quick install jamb brackets, skip this step and complete step fully adjustable jamb brackets.

Measure the length of the vertical tracks. Using the jamb bracket schedule, determine the placement of the jamb brackets for your door height and track length. To install the jamb brackets, align the Quick Install tab on the Quick Install jamb bracket with the Quick Install feature in the vertical track and turn the bracket perpendicular to the track so the mounting flange is toward the back (flat) leg of the track. Repeat for other side.

9100 / 9405 / 9600 / 5120 / 5145 / 6100 JAMB BRACKET SCHEDULE							
DOOR HEIGHT	TRACK LENGTH	1ST SET		2ND SET		3RD SET	
6'0"	57-3/4"	5	M	8	T	NA	
6'5"	62-3/4"	3	B	7	M	NA	
6'8"	66"	3	B	6	M	NA	
7'0"	69-1/2"	3	B	6	M	NA	
7'3"	72-1/2"	3	B	7	T	8	T
7'6"	75-1/2"	3	B	7	T	8	T
7'9"	78-1/2"	3	B	7	T	8	T
8'0" (4 Sect.)	81-1/2"	3	B	7	T	8	T
8'0" (5 Sect.)	82"	3	B	7	T	8	T

B= BOTTOM HOLE, M= MIDDLE HOLE, T= TOP HOLE

8000 JAMB BRACKET SCHEDULE							
DOOR HEIGHT	TRACK LENGTH	1ST SET		2ND SET		3RD SET	
6'0"	58-3/4"	9	M	11	M	NA	
6'3"	62"	9	B	11	M	NA	
6'6"	65-1/4"	9	M	10	B	NA	
6'9"	68"	9	M	10	B	NA	
7'0"	70"	9	M	10	B	NA	
7'6"	76-1/2"	9	T	10	M	11	M
7'9"	79-1/2"	9	T	10	M	11	M
8'0" (4 Sect.)	82-1/2"	9	T	10	M	11	M

B= BOTTOM HOLE, M= MIDDLE HOLE, T= TOP HOLE

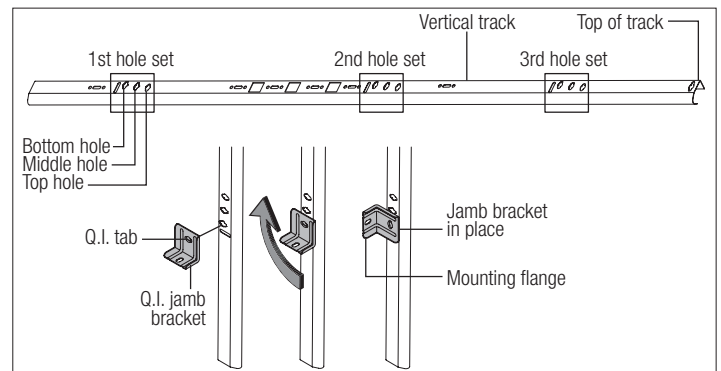

3

Fully Adjustable Jamb Brackets

Tools Required: Tape measure, Safety glasses, Leather gloves

NOTE: If quick install jamb brackets were installed, skip this step and continue with step windload jamb brackets. If not, complete this step.

NOTE: The bottom jamb bracket is always the shortest bracket, while the center jamb bracket is the next tallest. If three jamb brackets per side are included with your door, you will have received a top jamb bracket, which is the tallest.

To attach the bottom jamb bracket, locate lower hole of the hole/ slot pattern of the 1st hole set on the vertical track. Align the slot in the jamb bracket with the lower hole of the hole/ slot pattern. Secure jamb bracket using (1) 1/4" - 20 x 9/16" track bolt and (1) 1/4" - 20 flange hex nut. Repeat for other side.

Place the center jamb bracket over the lower hole of the hole/ slot pattern that is centered between the bottom jamb bracket and flag angle of the 2nd hole set. Secure jamb bracket using (1) 1/4" - 20 x 9/16" track bolt and (1) 1/4" - 20 flange hex nut. Repeat for other side.

If a top jamb bracket was included, secure it to vertical track using the lower hole of the hole/ slot pattern in the 3rd hole set and (1) 1/4" - 20 x 9/16" track bolt and (1) 1/4" - 20 flange hex nut. Repeat for other side.

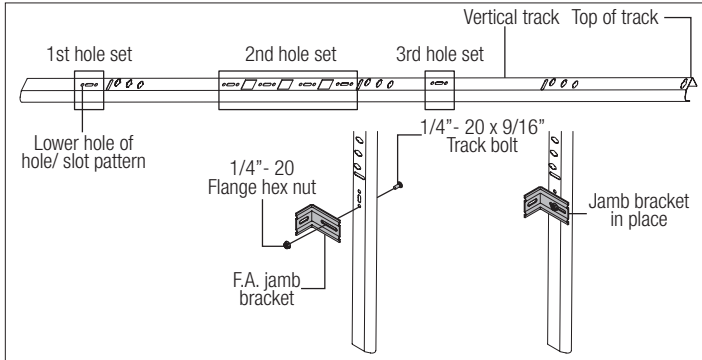

4

Windload Jamb Brackets

Tools Required: Tape measure, Safety glasses, Leather gloves

NOTE: If you do not have windload jamb brackets, skip this step and complete next step.

NOTE: Windload specification 0356 only uses the (QI) jamb bracket schedule.

NOTE: The following (JB) denotes a slotted jamb bracket.

Measure the length of the vertical tracks. Using the windload jamb bracket schedule, determine the placement of the jamb brackets for your door height and track type. Loosely fasten the windload jamb brackets to the vertical track with a 1/4" - 20 x 9/16" track bolt and 1/4" - 20 flange hex nut, as shown. Repeat for other side.

Windload (JB) Jamb Bracket Schedule				
Door Height	No. Of Sections	No. Of Jamb Brackets (Each Jamb)	Track Type	Location of center line of jamb brackets. Measured from bottom of track (All dimensions ± 2")
Windload Specification 0228				
7'-0" or Less	4	1	Q.I.	2" (JB), 63" (JB)
7'-1" to 8'-0"	4 Or 5	1	F.A.T.	2" (JB), 42" (JB), 63-1/4" (JB)
7'-0" or Less	4	1	Q.I.	2" (JB), 34" (JB)
7'-1" to 8'-0"	4 Or 5	1	F.A.T.	2" (JB), 10" (JB), 29-3/4" (JB), 48" (JB), 66" (JB)
Windload Specification 0229, 0600, & 0602				
7'-0" or Less	4	2	Q.I.	25-1/2" (JB), 63" (JB)
7'-1" to 8'-0"			F.A.T.	10" (JB), 21-3/4" (JB), 42" (JB), 63-1/4" (JB)
7'-0" or Less	4 Or 5	2	Q.I.	23" (JB), 34" (JB)
7'-1" to 8'-0"			F.A.T.	10" (JB), 21-3/4" (JB), 29-3/4" (JB), 48" (JB), 66" (JB)
Windload Specification 0230, 0232, 0233, 0234, 0601, 0603, 0607, & 0608				

Windload (JB) Jamb Bracket Schedule				
7'-0" or Less	4	4	Q.I.	2" (JB), 25-1/2" (JB), 34" (JB), 63" (JB)
			F.A.T.	2" (JB), 10" (JB), 21-3/4" (JB), 29-3/4" (JB), 42" (JB), 63-1/4" (JB)
7'-1" to 8'-0"	4 Or 5	5	Q.I.	2" (JB), 23" (JB), 34" (JB), 58" (JB), 75" (JB)
			F.A.T.	2" (JB), 10" (JB), 21-3/4" (JB), 29-3/4" (JB), 48" (JB), 57-1/4" (JB), 66" (JB), 75-1/2" (JB)
Windload Specification 0605				
7'-0" or Less	4	4	Q.I.	2" (JB), 23" (JB), 34" (JB), 58" (JB), 75" (JB)
7'-1" to 8'-0"	4 Or 5	5	F.A.T.	2" (JB), 10" (JB), 21-3/4" (JB), 29-3/4" (JB), 48" (JB), 57-1/4" (JB), 66" (JB), 75-1/2" (JB)

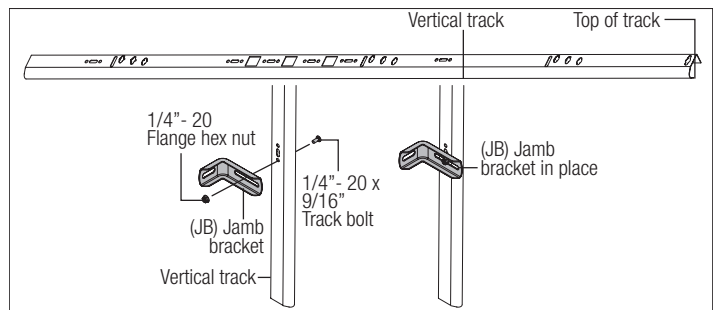

5

Top Fixtures

Tools Required: Power drill, 7/16" Socket driver, 7/16" Wrench, Phillips head screwdriver, Step ladder, Safety glasses, Leather gloves

Identify the low-headroom top fixtures provided with your door (A, B, C or D). Push the top section of door out against the jamb until the top section is parallel with the other sections of the door. Starting with the left hand side, align the edge of top fixture with the edge of section.

NOTE: When installing the top fixtures, the top section must be vertically aligned with the rest of the sections from the side view. If needed reposition top fixture (s) to achieve vertical alignment.

FOR LOW HEADROOM TOP FIXTURE (A):

Secure the low headroom top fixture to the top section by placing one 1/4" - 20 x 11/16" self drilling screw through the lower slot of top fixture. Adjust the low headroom top fixture if necessary. Secure two more 1/4" - 20 x 11/16" self drilling screws through the top holes, as shown. Repeat the same process for the other side.

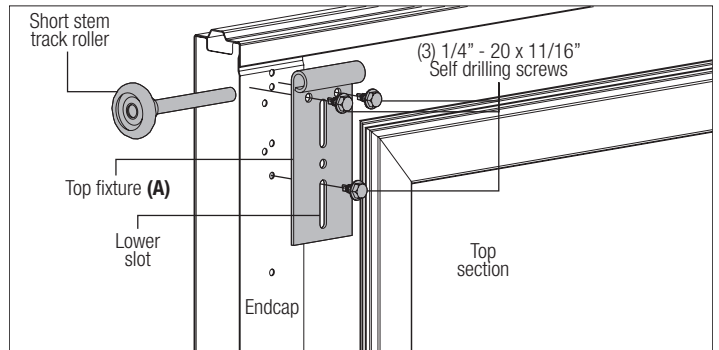

FOR LOW HEADROOM TOP FIXTURE (B) OR (C):

NOTE: The LHR top fixture comes pre-assembled, as shown.

Locate the edge of the top section and seat the top fixture on the male part of the top section, as shown.

ATTACH THE TOP FIXTURE TO THE TOP SECTION (B):

1. Attach one 1/4" - 20 x 11/16" self-drilling screw to the top fixture assembly.
 2. Attach two 1/4" - 20 x 11/16" self-drilling screws to the top fixture assembly.
 3. Attach two #12 x 1/2" phillips head screws on the opposite side of top fixture assembly.
- Insert a roller into the top fixture slide, as shown. Repeat the same process for the other side.

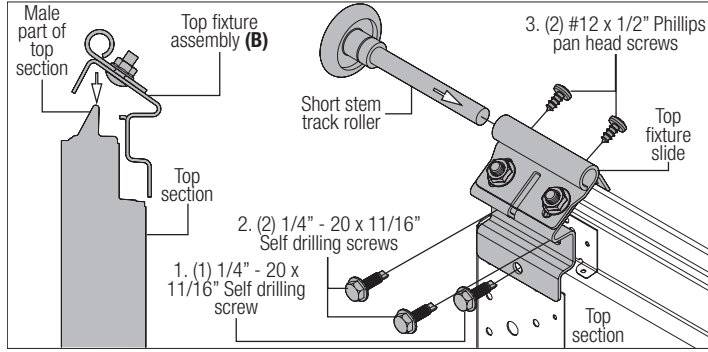

ATTACH THE TOP FIXTURE TO THE TOP SECTION (C):

1. Attach one 1/4" - 14 x 5/8" self-tapping screw to the top fixture assembly.
 2. Attach two 1/4" - 20 x 11/16" self-drilling screws to the top fixture assembly.
 3. Attach two #12 x 1/2" phillips head screws on the opposite side of top fixture assembly.
- Insert a roller into the top fixture slide, as shown. Repeat the same process for the other side.

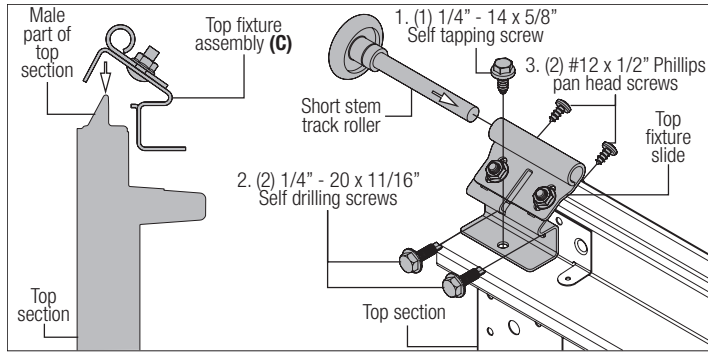

REVERSING THE TOP FIXTURE SLIDE (B) OR (C), IF NEEDED:

NOTE: Depending on your application, you may need to reverse the top fixture slide for more adjustment, if needed, prior to securing it to the top fixture base.

Remove the top fixture slide by removing the two 1/4" - 20 x 5/8" carriage bolts, two retention washers and two 1/4" - 20 flanged hex nuts. Flip the top fixture slide in the opposite direction. Loosely fasten the top fixture slide to the bracket using two 1/4" - 20 x 5/8" carriage bolts, two retention washers and two 1/4" - 20 flanged hex nuts, as shown.

NOTE: The retention washers must be fully seated against the top fixture base to ensure the anti-twist feature on the top fixture slide engages in the slotted hole in the top fixture base.

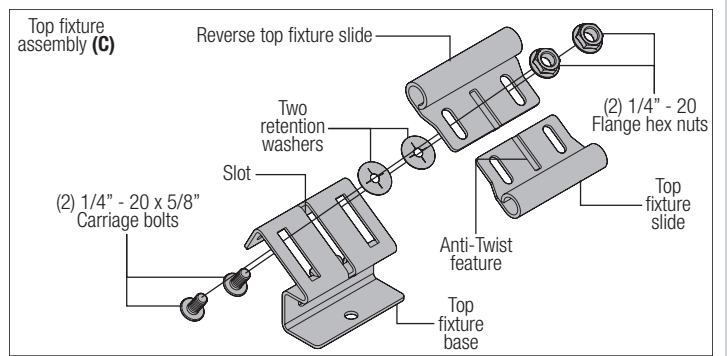
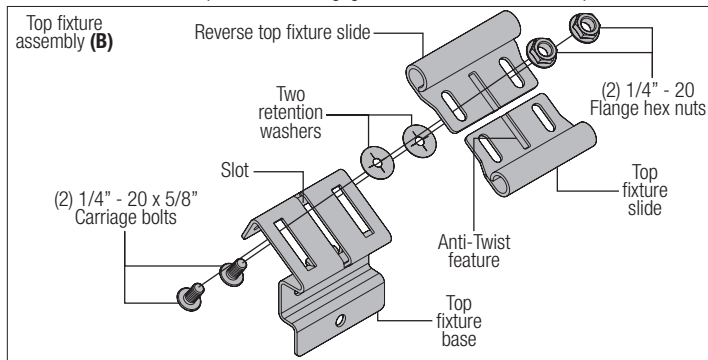

ATTACH THE TOP FIXTURE TO THE TOP SECTION (D):

NOTE: This is a traditional low headroom windload top fixture.

Vertically align the flat portion of roller slide with the endcap and strut at the top of the top section. Fasten the flat portion of the top fixture to the top section using (2) 1/4" - 20 x 7/8" self drilling screws, as shown. Repeat the same process for the other side.

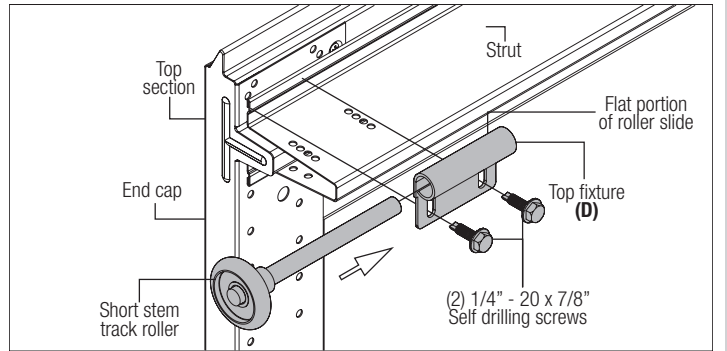

WARNING
DO NOT RAISE DOOR UNTIL HORIZONTAL TRACKS ARE SECURED AT REAR, AS OUTLINED IN REAR SUPPORT INSTALLATION, OR DOOR COULD FALL FROM OVERHEAD POSITION CAUSING SEVERE OR FATAL INJURY.

6 Horizontal tracks
 Tools Required: Ratchet wrench, 9/16" 7/16" Socket, 9/16" 7/16" Wrench, Step ladder, Tape measure, Safety glasses, Leather gloves

To install horizontal track, align the bottom of the horizontal track with the top of the vertical track.

Q.I. FLAGANGLE: Align the key slot in each horizontal track with the quick install tabs on the corresponding flagangle. Push the curved portion of the horizontal downward to lock into place, as shown.

FULLY ADJUSTABLE FLAGANGLE: Secure each horizontal track to the corresponding flagangle with (2) 1/4" - 20 X 9/16" large head track bolts and (2) 1/4" - 20 flanged hex nuts, as shown.

Level horizontal track and secure the upper curve to the flagangle using (1) 1/4" - 20 x 9/16" track bolt, (1) 5/16" flat washer and (1) 1/4" - 20 flanged hex nut, as shown. Repeat for other side.

NOTE: Check the clearance between the upper curve and the jamb. The clearance must be a minimum of 5/8", as shown. If it is less than 5/8" trim the top curve with a hacksaw.

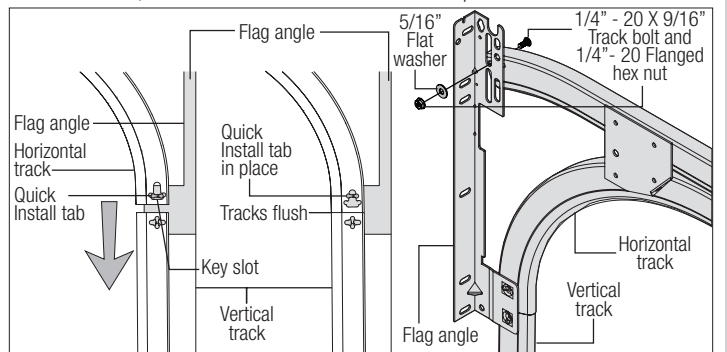

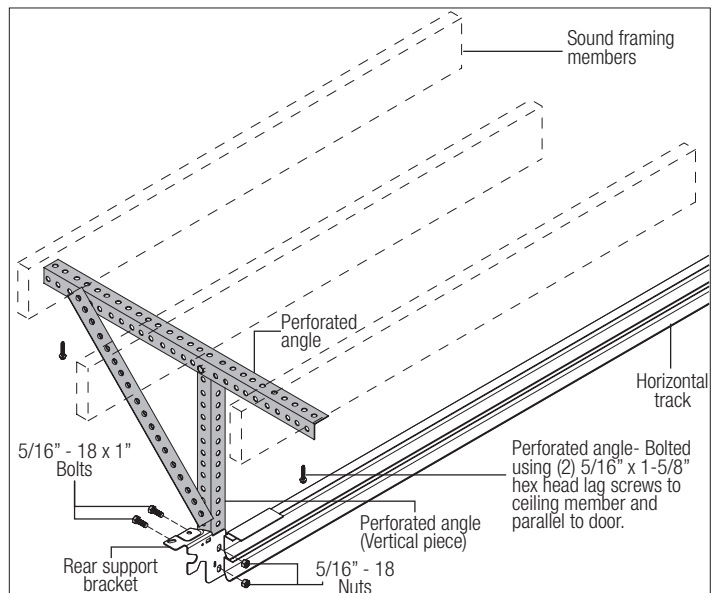
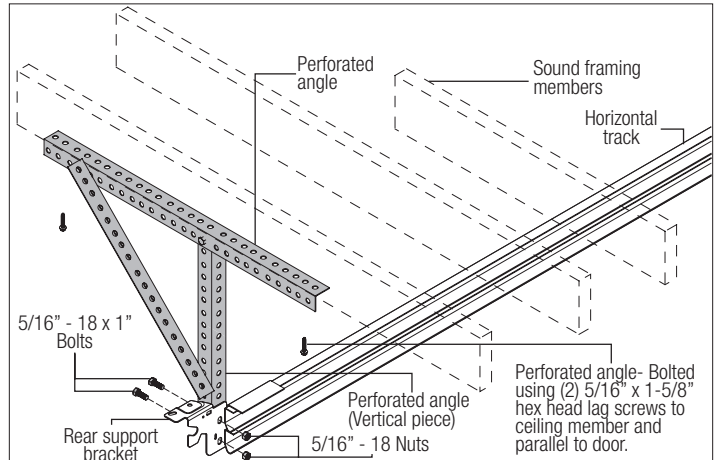
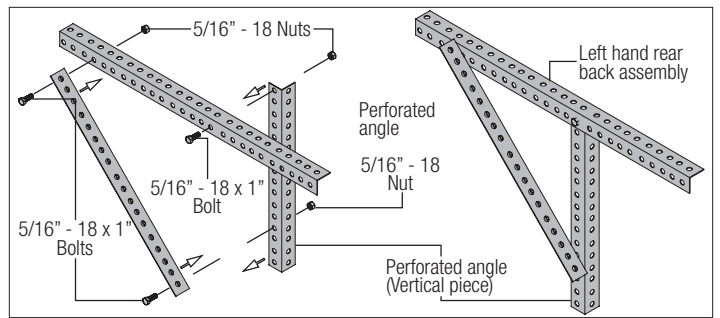
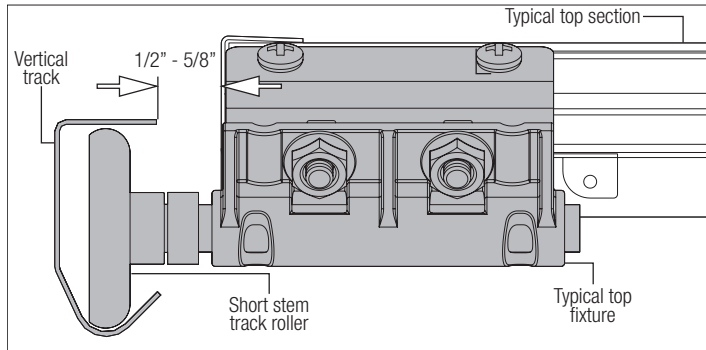
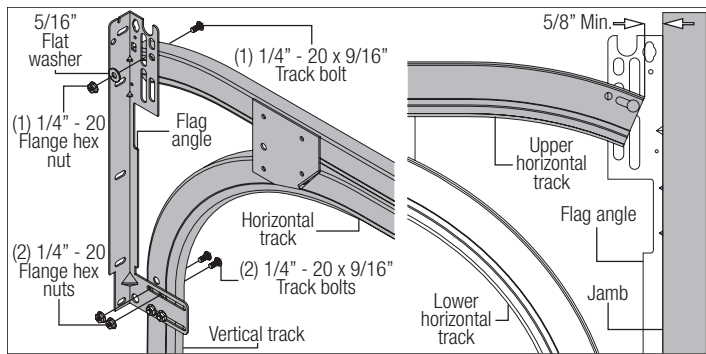

7 Rear Back Hangs

Tools Required: Ratchet wrench, Socket: 1/2" 5/8", Wrench: 1/2" 5/8", (2) Vice clamps, Step ladder, Tape measure, Safety glasses, Leather gloves

IMPORTANT: HOLD THE DOOR DOWN TO PREVENT IT FROM RISING UNEXPECTEDLY IN THE EVENT THE SPRING(S) WAS OVER-WOUND AND CAUTIOUSLY REMOVE VICE CLAMPS FROM VERTICAL TRACKS.

Raise the door until the top section and half of the next section are in the horizontal track radius. Do not raise door any further since rear of horizontal tracks are not yet supported.

WARNING
RAISING DOOR FURTHER CAN RESULT IN DOOR FALLING AND CAUSING SEVERE OR FATAL INJURY.

Clamp a pair of vice clamps onto the vertical tracks just above the second track roller on one side and just below the second track roller on the other side. This will prevent the door from raising or lowering while installing the rear back hangs. Using perforated angles, 5/16" x 1-5/8" lag screws and 5/16" - 18 x 1" hex head bolts with 5/16" - 18 nuts (may not be supplied), fabricate rear supports for horizontal tracks, as shown.

Attach rear supports to ceiling joist or other structurally sound framing members, making sure the vertical piece is positioned with the back leg angled outward and away from the door opening. Attach rear support to the rear support bracket with two 5/16" - 18 x 1" hex head bolts and 5/16" - 18 nuts. Horizontal tracks must be level and parallel with door, as shown.

NOTE: Ensure the two 5/16" - 18 x 1" hex head bolts is going through the vertical piece first, then through the rear support bracket and the 5/16" - 18 nuts is in the inside of the horizontal track, as shown.

IMPORTANT: LATERAL BRACE MUST ALWAYS BE USED TO PREVENT SWAYING OF THE HORIZONTAL TRACK.

NOTE: If an automatic garage door opener will be installed, position horizontal tracks one hole above level when securing to the rear support.

IMPORTANT: SPACING BETWEEN THE LEFT AND RIGHT HAND TORQUEMASTER® ADAPTER BRACKETS MUST BE DOOR WIDTH PLUS 5-3/8" (136MM).

WARNING
KEEP HORIZONTAL TRACKS PARALLEL AND WITHIN 3/4" - 7/8" (19MM - 22MM) OF DOOR EDGE, OTHERWISE DOOR COULD FALL, RESULTING IN SEVERE OR FATAL INJURY.

8 Cable Lift Sheaves

Tools Required: Ratchet wrench, 3/8" Socket, 3/8" Wrench, Step ladder, Safety glasses, Leather gloves

Place a 3/8" - 16 x 1-1/2" truss head bolt through the sheave plate hole in the horizontal track and slide the sheave over the end of the bolt, as shown. Secure the sheave using (1) 3/8" - 16 hex nut. Repeat for the other side and loop the counterbalance lift cables over each sheave.

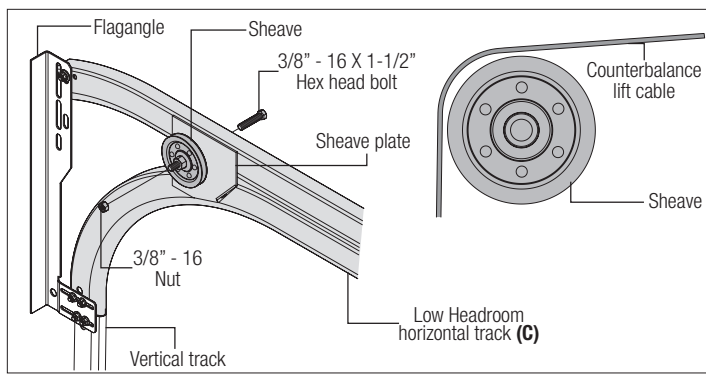

9 TorqueMaster® Spring Tube

Tools Required: Safety glasses, Leather gloves

TorqueMaster® springs come lubricated and pre-assembled inside the TorqueMaster® spring tube. To prepare for install, lay the spring tube assembly on the floor, inside garage, in rear of the door, and with the labeled end to the left. Next, remove the shipping boots from the ends of the TorqueMaster® spring tube.

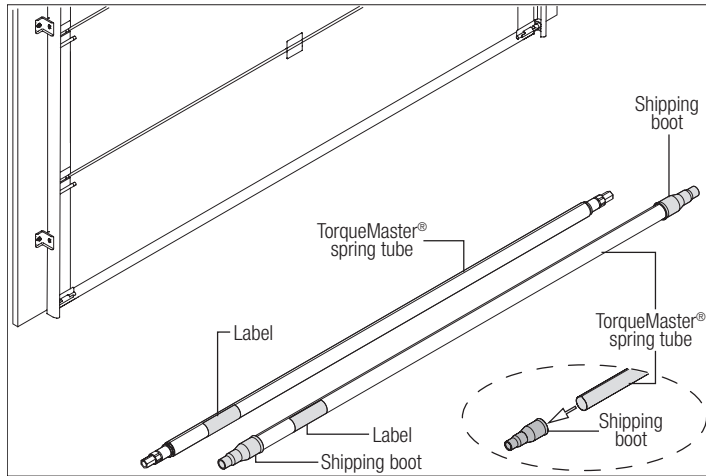

10 Center Bracket Bushing Assembly

Tools Required: Safety glasses, Leather gloves

Being cam shaped, the center bushing only fits one way. Slide the center bracket bushing assembly towards the center of the TorqueMaster® spring tube, from the right side, as shown.

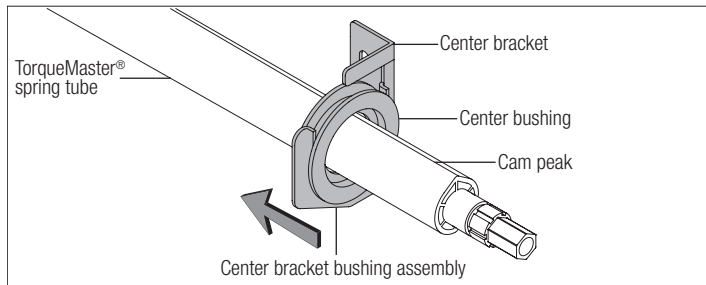

11 Reinforcing Bracket (if included)

Tools Required: Ratchet wrench, 3/8" Socket, 3/8" Wrench, Step ladder, Safety glasses, Leather gloves

NOTE: If reinforcing brackets are included, install them according to these instructions. If reinforcing brackets were not included, skip this step and continue with the TorqueMaster® Spring Tube Installation.

Starting on the left hand side, position the reinforcing bracket on top of the left hand rear support bracket. Insert (2) 5/16" - 18 x 1" hex head bolts through the reinforcing bracket and perforated angle and (2) 5/16" - 18 hex nuts, as shown. Tighten the nuts and repeat for the same process for the right hand side.

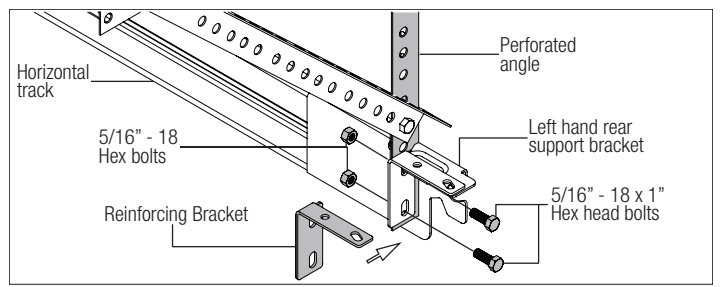

12 Cable Drum Assemblies

Tools Required: Tape measure, Step ladder, Safety glasses, Leather gloves

Shake the TorqueMaster® spring tube assembly gently to extend the winding shafts out about 5" on each side. For **single spring applications**, there will be no left hand spring in the TorqueMaster® spring tube assembly. Lift the TorqueMaster® spring tube assembly and rest it on top of the rear support brackets.

NOTE: Cable drum assemblies are marked right and left hand. Cable drums and TorqueMaster® spring tube assembly are cam shaped to fit together only one way.

Starting on the right hand side, slide the drum wrap over to access the counterbalance lift cable. Pre-wrap the cable drum with the counterbalance lift cable 1-1/2 wraps, as shown.

Position the TorqueMaster® spring tube assembly so the cam peak is pointing towards the door sections. Slide the cable drum over the winding shaft until the cable drum seats against the TorqueMaster® spring tube assembly.

The winding shaft must extend past the cable drum far enough to expose the splines and the grooves. Align the winding shaft grooves with the round notch in the rear support bracket.

FOR DOUBLE SPRING APPLICATIONS: Repeat for left hand side.

FOR SINGLE SPRING APPLICATIONS: Position and insert the idler bracket into the right hand cable drum, as shown. Lightly press the idler bracket into the cable drum until a distinctive snap is heard.

IMPORTANT: ENSURE THE SNAPS ON THE IDLER BRACKET (LEFT HAND SIDE) ARE ENGAGED INTO THE LEFT HAND CABLE DRUM, SO THAT IT DOES NOT COME BACK OUT.

Pre-wrap the left hand cable drum with the counterbalance lift cable 1-1/2 wraps and slide the cable drum over the TorqueMaster® spring tube assembly. Slide the TorqueMaster® spring tube assembly into the cable drum until the cable drum seats up against the TorqueMaster® spring tube assembly.

NOTE: The idler bracket must extend past the cable drum far enough to expose the groove.

Align the idler bracket groove with the round notch in the rear support bracket.

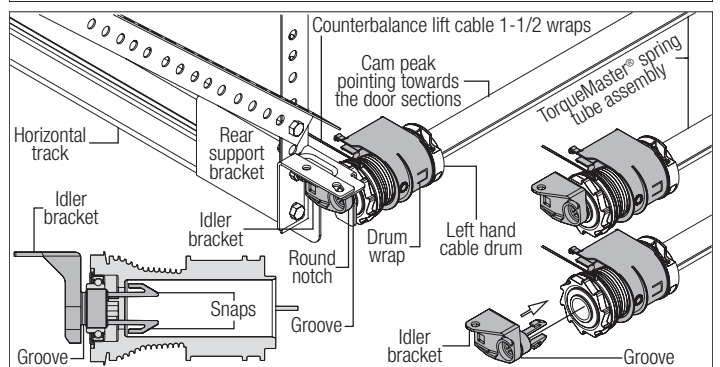
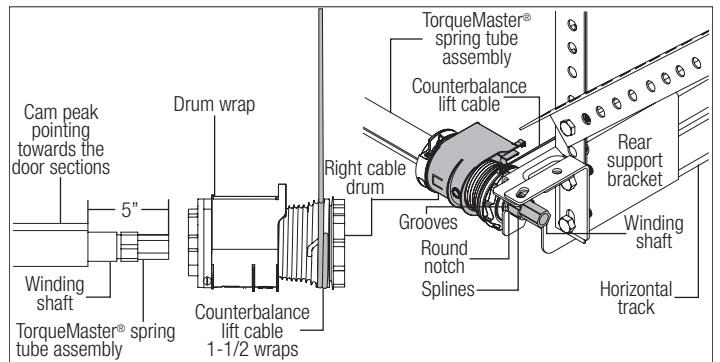

13 End Brackets

Tools Required: Power drill, 7/16" Socket driver, 1/2" Wrench, Step ladder, Safety glasses, Leather gloves

IMPORTANT: WARNING TAGS MUST BE SECURELY ATTACHED TO END BRACKET(S).

You can identify the right hand end bracket by the disconnect cable guide hole, located at the top of the end bracket.

NOTE: On single spring applications, no ratchet wheel is required on the left hand side.

Beginning with the right hand side, slide the end bracket onto the winding shaft so that the splines in the ratchet wheel fit onto the winding shaft grooves.

NOTE: If ratchet wheel falls out of end bracket, refer to illustration for proper insertion orientation.

Attach the end bracket to the rear support bracket and the reinforcing bracket (if included) using (1) 5/16" - 18 x 1" hex head bolt and (1) 5/16" - 18 hex nut, as shown.

NOTE: Ensure the 5/16" - 18 x 1" hex head bolt is going through the end bracket first and the 5/16" - 18 nut is on top of the rear support bracket or the reinforcing bracket (if included).

Now secure the end bracket to the rear support bracket using (1) 1/4" - 20 x 9/16" track bolt, (1) 5/16" flat washer and (1) 1/4" - 20 flange hex nut.

NOTE: Ensure the 1/4" - 20 x 9/16" track bolt is going through the inside of rear support bracket first, then the 5/16" flat washer and the 1/4" - 20 flange hex nut is on the outside of the rear support bracket.

FOR DOUBLE SPRING APPLICATIONS: Repeat same process for left hand end bracket.

FOR SINGLE SPRING APPLICATIONS: Secure the idler bracket to the rear support bracket and the reinforcing bracket (if included) using (1) 5/16" - 18 x 1" hex head bolt and (1) 5/16" - 18 hex nut. Next secure the end bracket to the rear support bracket using (1) 1/4" - 20 x 9/16" track bolt, (1) 5/16" flat washer and (1) 1/4" - 20 flange hex nut, as shown.

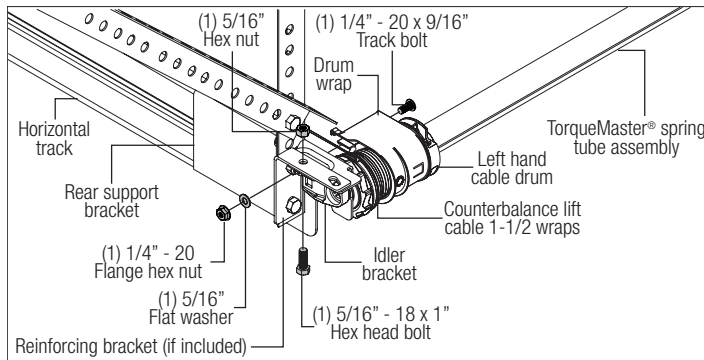
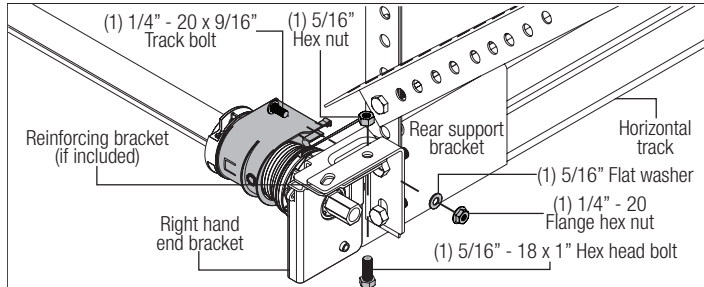
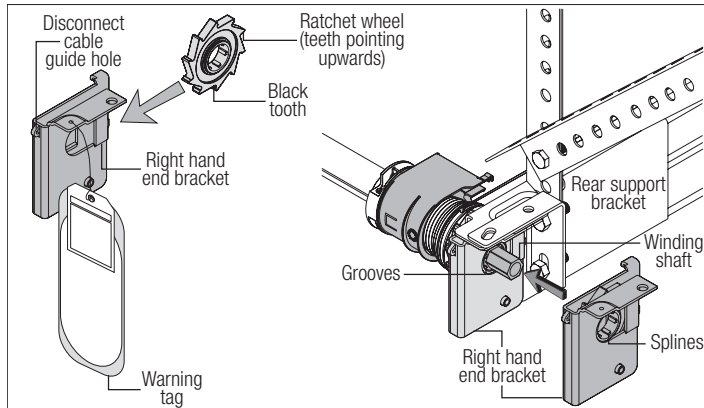

not be supplied), keeping the TorqueMaster® spring tube level.

NOTE: See provided installation manual for instructions on how to adjust cables prior to winding the springs on the Torquemaster® counterbalance system.

NOTE: See provided installation manual for instructions on how to wind the springs of the Torquemaster® Plus counterbalance system.

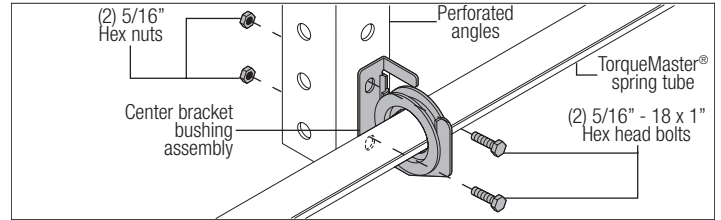

14 Securing Center Bracket Bushing Assembly

Tools Required: 3/8" Wrench, Step ladder, Level, Safety glasses, Leather gloves

IMPORTANT: TORQUEMASTER® SPRING TUBE MUST BE LEVEL BEFORE SECURING CENTER BRACKET BUSHING ASSEMBLY.

Locate the center of the TorqueMaster® spring tube and secure a perforated angle set to the ceiling, similar to the rear back hangs (refer to step, Rear Back Hangs), as near to the center bracket bushing assembly location as possible. Slide the center bracket bushing assembly to the center of the TorqueMaster® spring tube. Position the center bracket assembly onto the perforated angle and secure using (2) 5/16" - 18 x 1" bolts and (2) 5/16" - 18 hex nuts (may